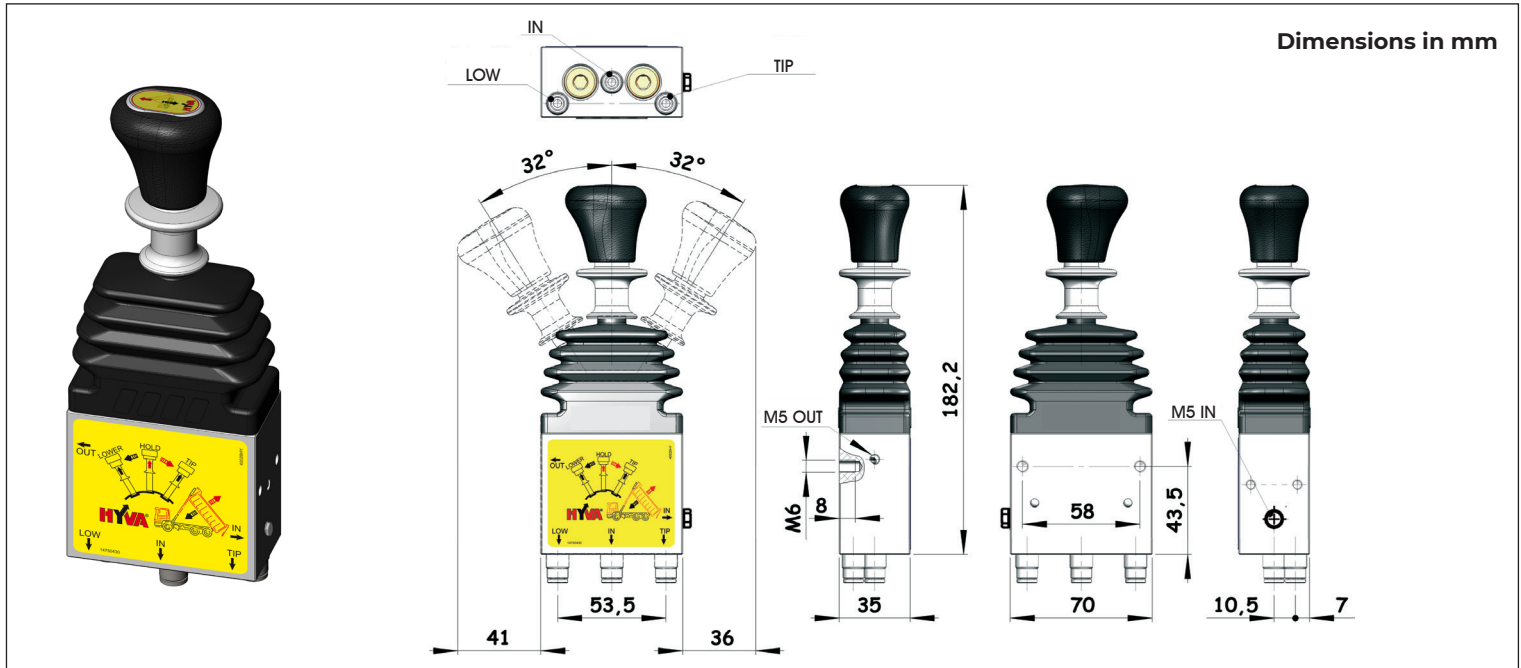

type : air proportional, 2 or 3 position
 sandwich controls rear ports

Specifications

Max. pressure	= 12 bar
Min. pressure	= 5 bar
Max. temperature	= + 80°
Min temperature	= - 30°
Fluid	= air
Working pressure	= 12 bar max

Part no.	Description	Qty
14750420	air control MS-TF/LF	1
14750430	air control MS-TF/LF (BASE)*	1
14750430-1	air control MS-TF/LS (BASE)*	1
14750440	air control MS-TS/LF (BASE)*	1
14750442	air control MS-TS/LS	1

Explanation of codes:

TF	= lever is fixed in tipping end position
TS	= lever has a spring return in tip position
LF	= lever is fixed in lowering end position
LS	= lever has a spring return in low position

General Info
note:

* The air control with fixed position (TF or LF) is not allowed to be used on a tipper in the EU according Machinery Directive 2006/42/EC, chapter 3.3.1.

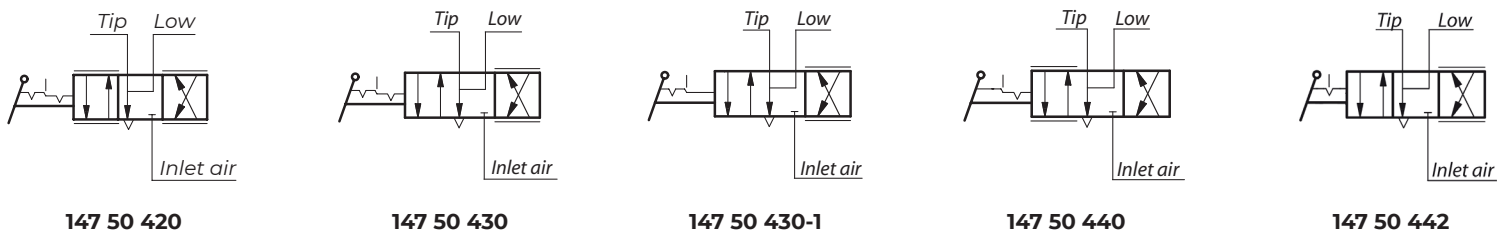
Pneumatic symbol

Related documentation

Mounting instructions: AIR-0003